



TILLOTSON LTD., CLASH INDUSTRIAL ESTATE,
TRALEE, CO. KERRY, IRELAND

PHONE: +353 66 7121911 FAX: +353 66 7124503

e-mail: sales@tillotson.ie



PARTS LIST

Last update: JULY 2000

Illustration of basic parts standard throughout HR series carburettor.
For individual model listing see following pages.

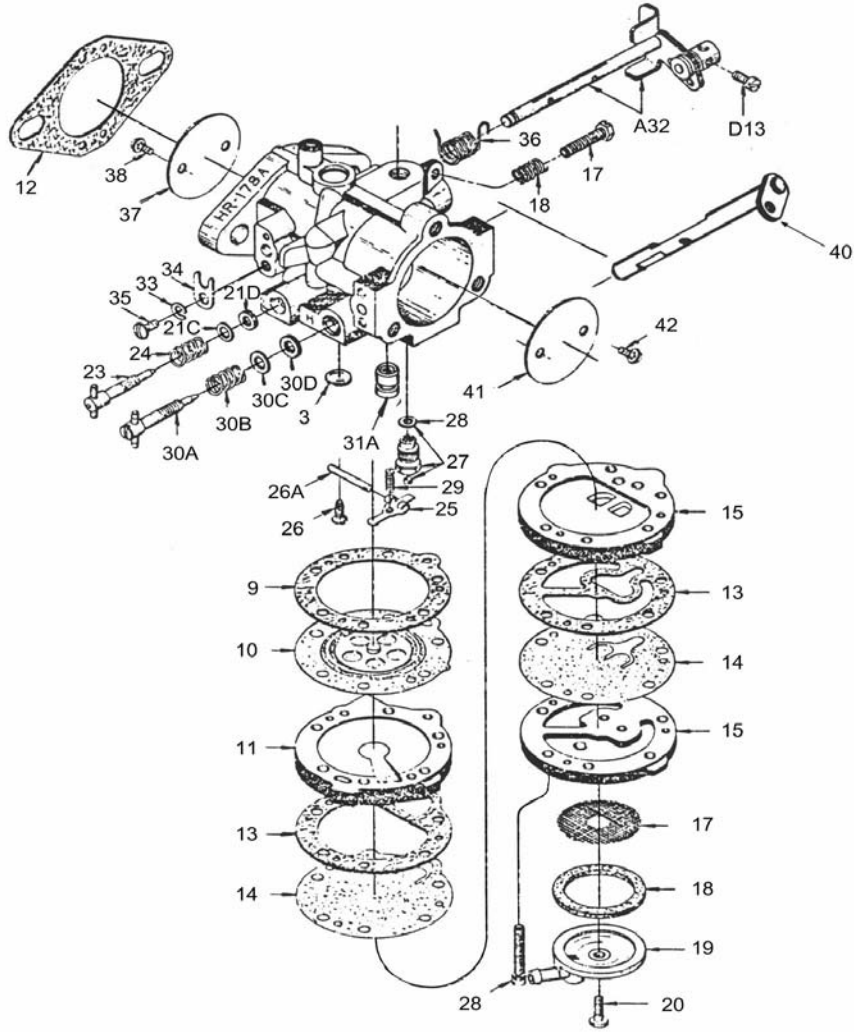

Parts illustrated are typical in appearance
and may not look exactly like the part required

Carburetor Model		HR-181B	HR-194A	HR-195A
Customer				
Equipment Model No.				
Venturi		27.8MM	27.8MM	
Ref. No.	Part Name			
*3	Body Channel Welch Plug	179-55	179-55	179-55
+*9	Diaphragm Gasket	16B-217	16B-217	16B-217
+*10	Diaphragm	237-680	237-600	237-600
11	Diaphragm Cover Assembly	91-1000	91-1000	91-1000
+*12	Flange Gasket	16B-241	16B-241	16B-241
+*13	Fuel Pump Gasket	16B-252	16B-252	16B-252
+*14	Fuel Pump Diaphragm	237-154	237-154	237-154
15	Fuel Pump Body	198-322	198-322	198-322
17	Fuel Strainer Screen	95-174	95-174	95-174
*18	Fuel Strainer Cover Gasket	16B-205	16B-205	16B-205
19	Fuel Strainer Cover	91A-351	91A-351	91A-351
20	Fuel Strainer Cover Retaining Screw	15B-313	15B-313	15B-313
21A	Idle Mixture Screw	43-991	43-991	43-991
21B	Idle Mixture Screw Spring	24B-247	24B-247	24B-247
21C	Idle Mixture Screw Washer	78A-256	78A-256	78A-256
D17	Idle Mixture Screw Washer	78A-226		
21D	Idle Mixture Screw Packing	44-270	44-270	44-270
23	Idle Speed Screw	15B-338	15B-338	15B-338
24	Idle Speed Screw Spring	24B-131	24B-131	24B-131
*25	Inlet Control Lever	155A-27	155A-27	155A-27
26A	Inlet Control Lever Fulcrum Pin	32-79	32-79	32-79
26	Inlet Control Lever Fulcrum Screw	15B-329	15B-329	15B-329
*27	Inlet Needle, Seat & Gasket	233-710	233-710	233-710
28	Inlet Seat Gasket	16B-199	16B-199	16B-199
29	Inlet Tension Spring	24B-345	24C-269	24C-269
29A	Inlet Valve Body	67-38	67-38	67-38
29B	Inlet Valve Body Screw (6)	15B-343	15B-343	15B-343
+*29C	Inlet Valve Diaphragm	237-155	237-155	237-155
+*29D	Inlet Valve Gasket	16B-253	16B-253	16B-253
30A	High Speed Mixture Screw	43-987	43-987	43-987
30B	High Speed Mixture Screw Spring	24B-449	24B-449	24B-449
30C	High Speed Mixture Screw Washer	78A-256	78A-226	78A-226
30D	High Speed Mixture Screw Packing	44-270	44-277	44-277
31A	Nozzle Check Valve	363-508	363-508	363-508
A32	Throttle Shaft/Lever Assembly	13-2084	13-2084	13-2084
33	Throttle Shaft Clip Lockwasher	29-218	29-218	29-218
34	Throttle Shaft Clip	78A-239	78A-239	78A-239
35	Throttle Shaft Clip Ret. Screw	15C-18	15C-18	15C-18
36	Throttle Shaft Return Spring	24B-357	24B-357	24B-357
37	Throttle Shutter	14-415	14-415	14A-52
38	Throttle Shutter Screw	15C-29	15C-29	15C-29
D13	Throttle Wire Ret. Screw	15B-325	15B-325	15B-325
40	Choke Shaft Assembly		26-1277	26-1277
	Choke Shaft 'E' Ring		29-220	29-220
	Choke Shaft Return Spring		24C-233	24C-233
41	Choke Shutter		27-377	27-325
42	Choke Shutter Screw			15C-29
	Bracket Clamp Screw			15C-43
	Clamp Screw Washer			78A-355
	Primer Bulb Assembly			362-504
	Repair Kit	RK-103HL		RK-103HL
	Diaphragm & Gasket Set	DG-4HL/R		DG-4HL/R

*Indicates contents of Repair Kit

+Indicates contents of Diaphragm & Gasket Set

