

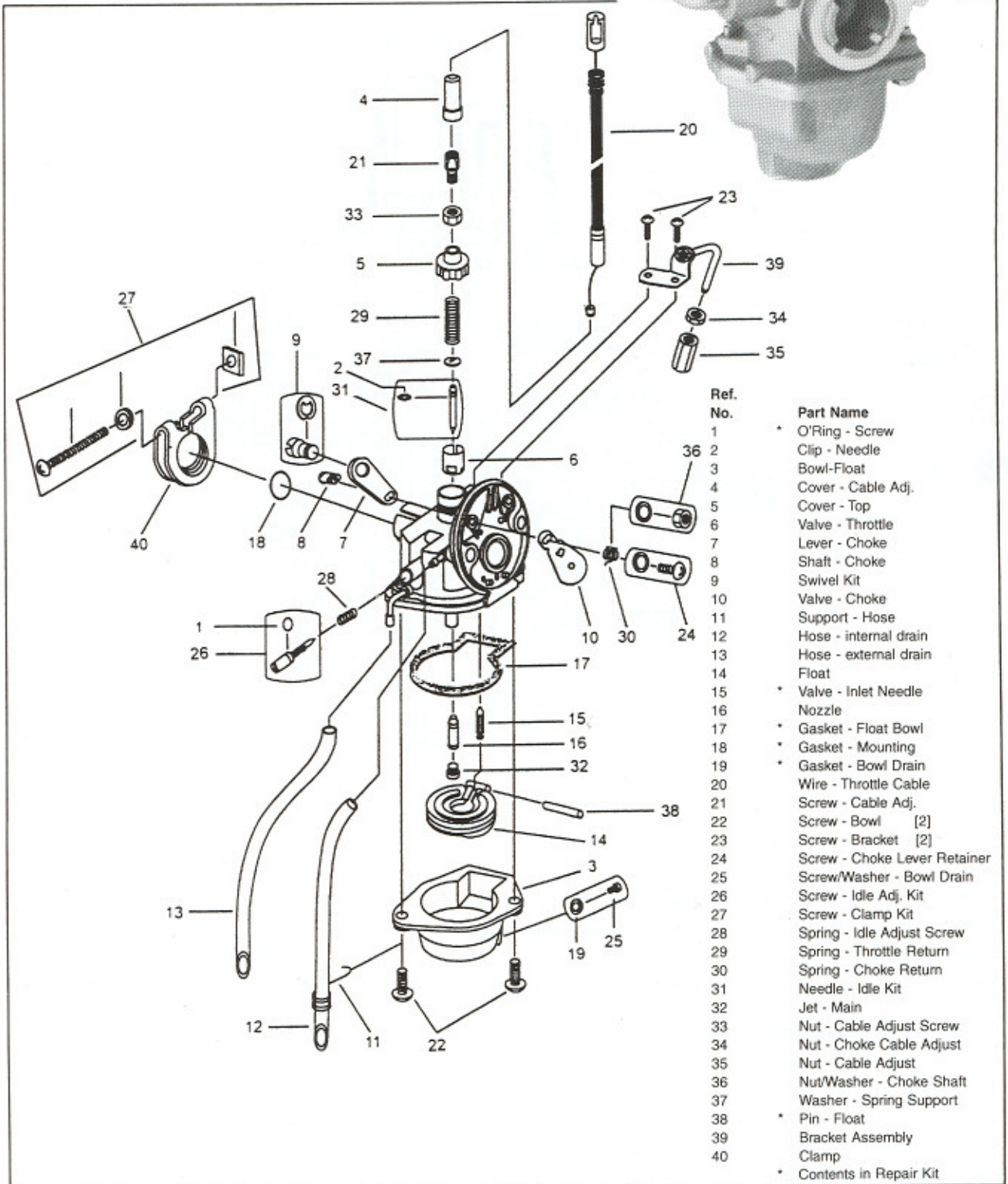

TRIMMER AND
BLOWER MODEL
CARBURETOR
SERVICE MANUAL

WPF series

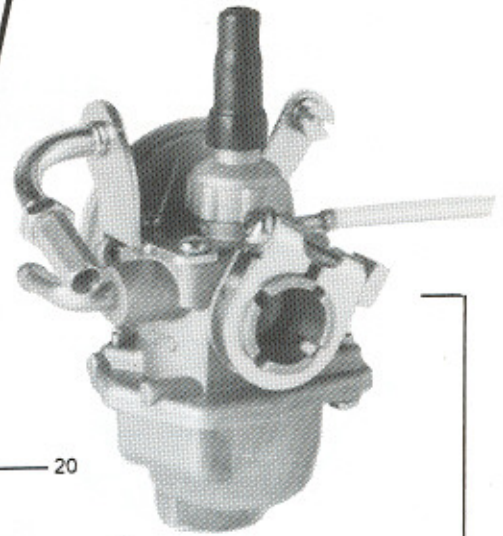

Ref. No.	Part Name
1	O'Ring - Screw
2	Clip - Needle
3	Bowl-Float
4	Cover - Cable Adj.
5	Cover - Top
6	Valve - Throttle
7	Lever - Choke
8	Shaft - Choke
9	Swivel Kit
10	Valve - Choke
11	Support - Hose
12	Hose - internal drain
13	Hose - external drain
14	Float
15	Valve - Inlet Needle
16	Nozzle
17	Gasket - Float Bowl
18	Gasket - Mounting
19	Gasket - Bowl Drain
20	Wire - Throttle Cable
21	Screw - Cable Adj.
22	Screw - Bowl [2]
23	Screw - Bracket [2]
24	Screw - Choke Lever Retainer
25	Screw/Washer - Bowl Drain
26	Screw - Idle Adj. Kit
27	Screw - Clamp Kit
28	Spring - Idle Adjust Screw
29	Spring - Throttle Return
30	Spring - Choke Return
31	Needle - Idle Kit
32	Jet - Main
33	Nut - Cable Adjust Screw
34	Nut - Choke Cable Adjust
35	Nut - Cable Adjust
36	Nut/Washer - Choke Shaft
37	Washer - Spring Support
38	Pin - Float
39	Bracket Assembly
40	Clamp
	* Contents in Repair Kit

Form E-1124

WALBRO WPF CARBURETOR

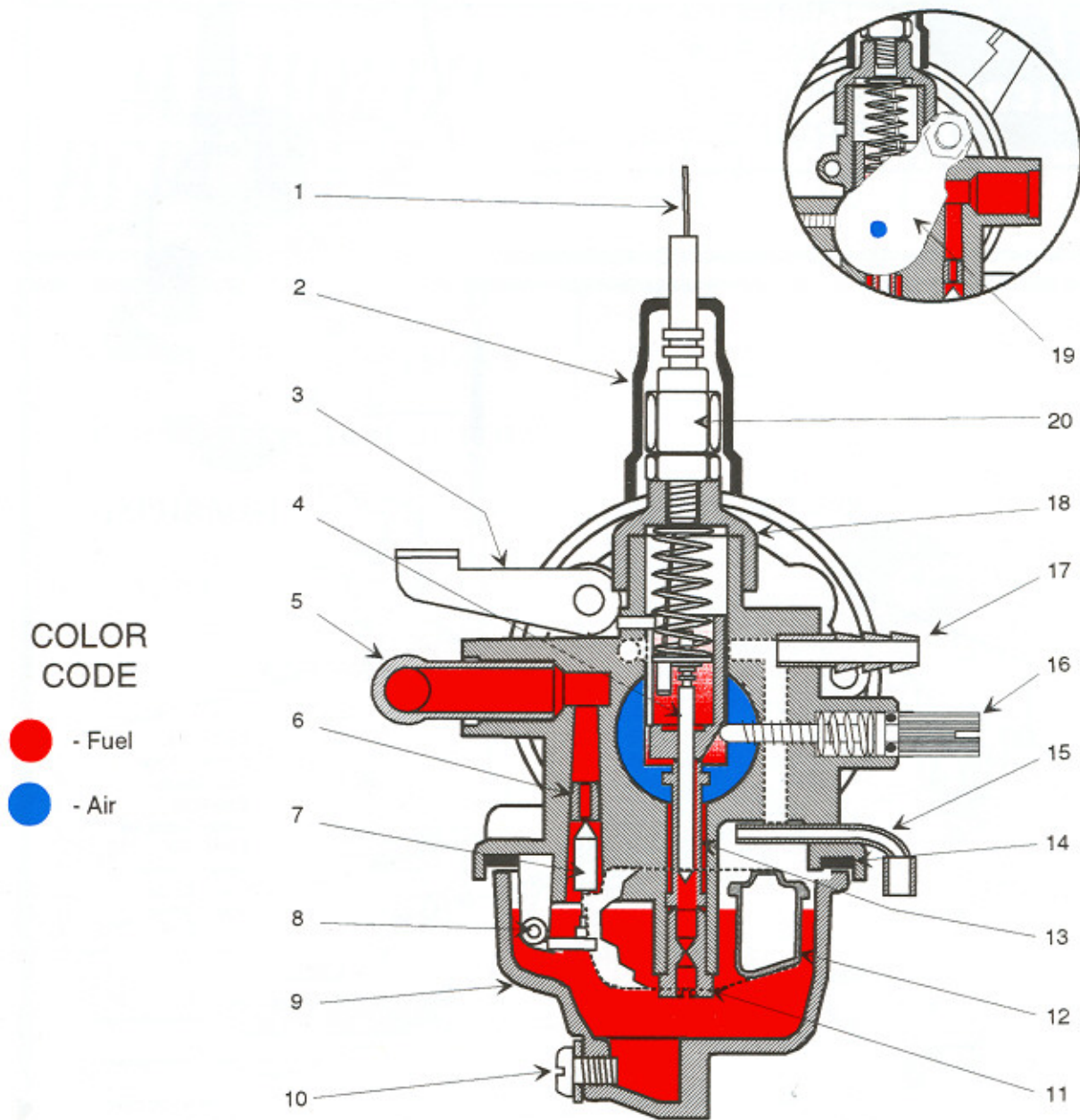

COLOR CODE

- - Fuel
- - Air

WPF OPERATING FUNCTIONS

1. Throttle Linkage: Controls position of throttle slide barrel for all performance positions.
2. Throttle Cable Cover: Protects throttle linkage connection from dirt and damage.
3. Choke Lever: Controls function of choke assembly at starting position.
4. Metering Needle Assembly: Increases or decreases air flow by adjusting slide barrel accordingly.
5. Fuel Inlet Fitting: Fuel drawn from tank enters here.
6. Inlet Needle Seat: Allows passage of fuel to enter from bowl.
7. Inlet Needle: When lifted off seat, allows correct amount of fuel to enter fuel bowl.
8. Float Hinge Pin: Allows float to move free at its functioning positions.
9. Float Bowl: Holds correct amount of fuel entering from tank.
10. Bowl Drain Screw: Allows user to remove stale or contaminated fuel from bowl.
11. Main Jet: Controls amount of fuel allowed to enter engine at wide open throttle position.
12. Float Assembly: Regulates amount of fuel allowed in the fuel bowl.
13. Nozzle: Controls delivery of fuel to idle and wide open throttle systems.
14. Bowl Gasket: Seals bowl at assembly.
15. Overflow Tube: Prevents over-rich mixture due to high vibration.
16. Idle Speed Screw: Controls idle rpm.
17. Bowl Vent: Relieves pressure that can build up in float bowl.
18. Top cover: Retains throttle valve (slide) assembly to carb body.
19. Choke Plate: Controls amount of air entering carburetor at start position.
20. Throttle Cable Adj. Nut: Eliminates play in throttle cable linkage.

WPF AT START (CHOKE) POSITION

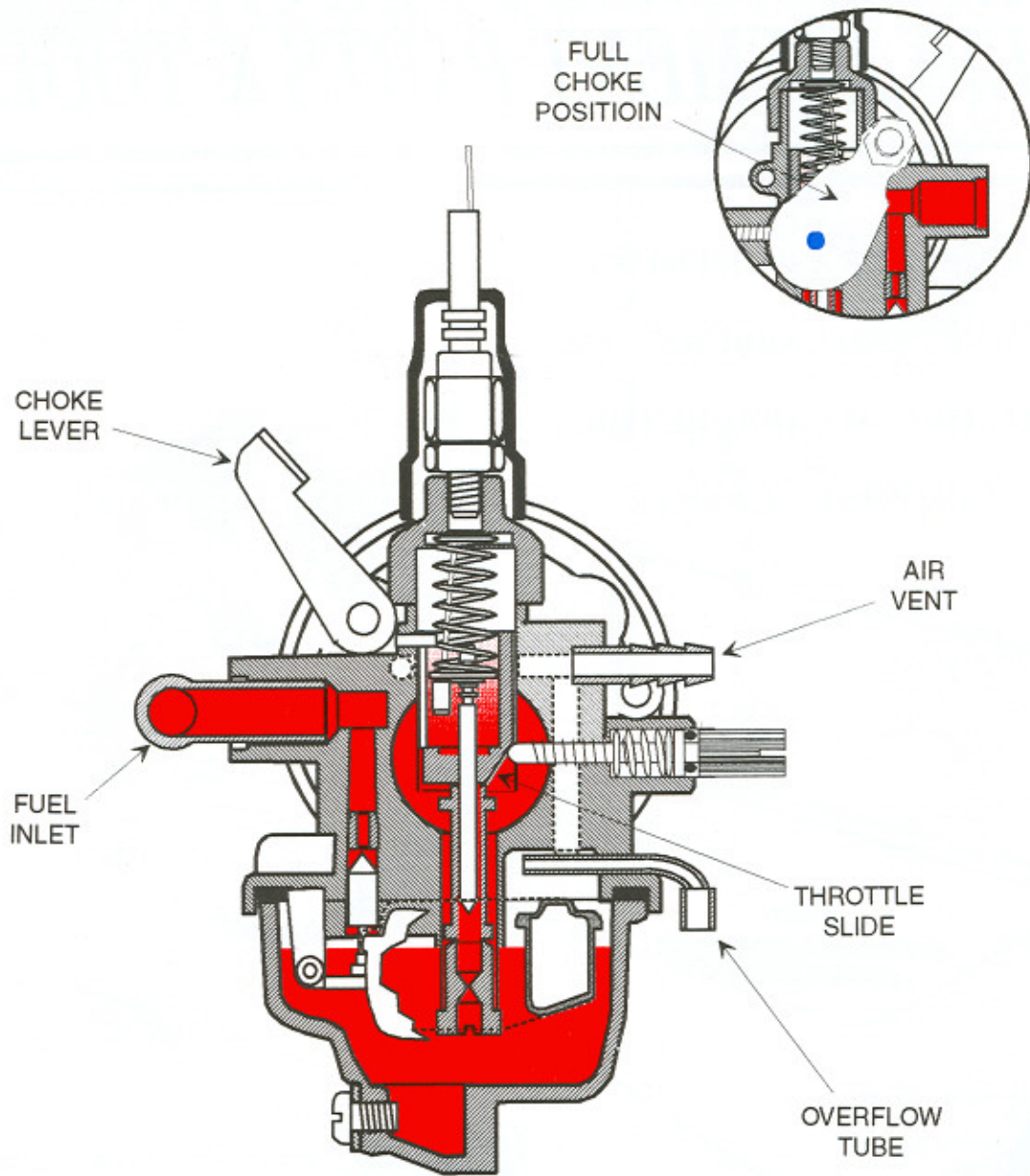

WPF STARTING PROCEDURE

The WPF carburetor has a slide choke that is opened and closed manually. To start the engine, the slide choke must be closed to completely cover the choke bore. This allows the manifold vacuum to draw into the crankcase and combustion chamber primarily fuel to fire the engine. Once the engine has fired, open the choke. Restart the engine and allow it to idle momentarily before adjusting for the correct idle.

WPF AT IDLE POSITION

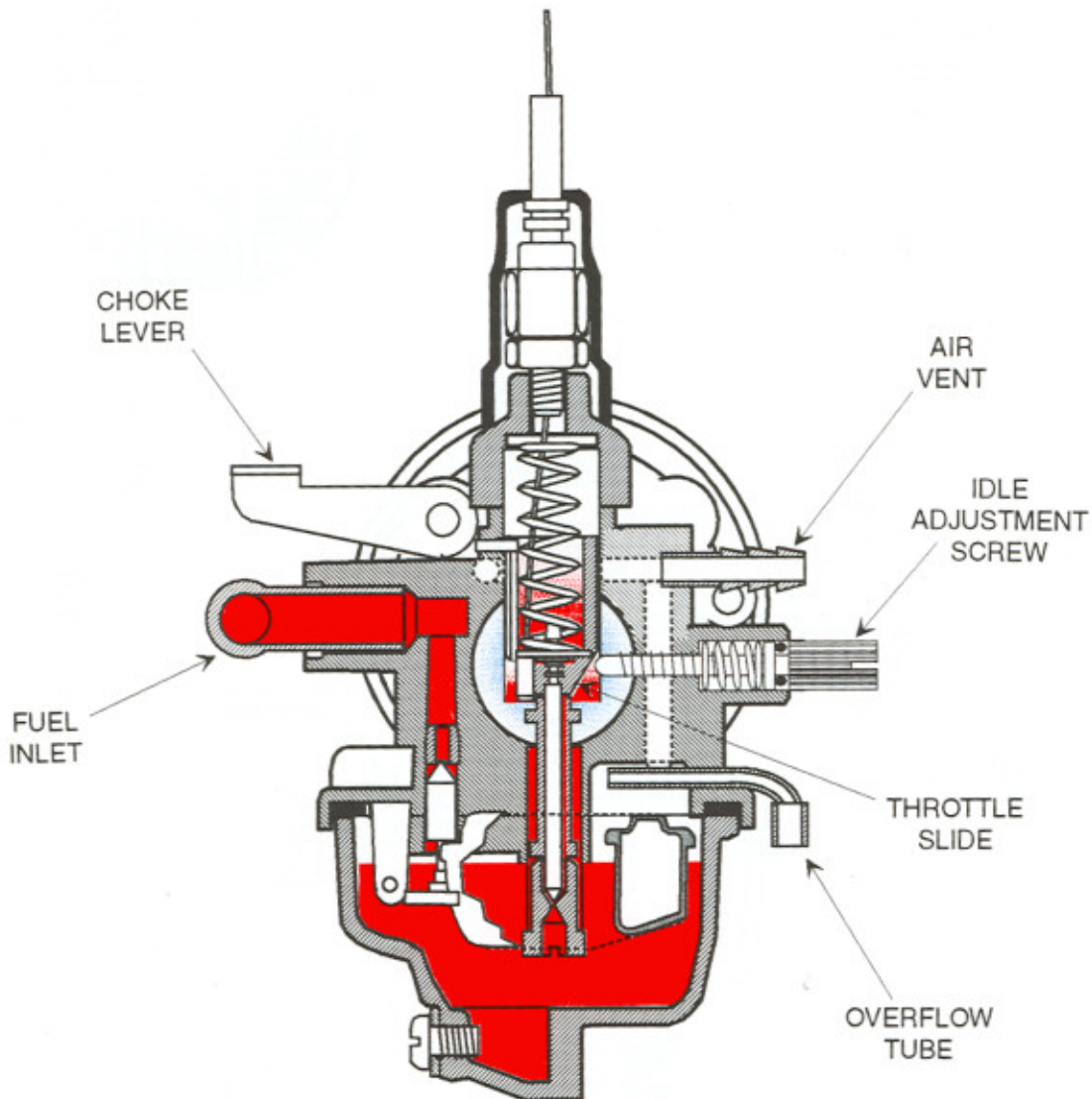

WPF AT IDLE POSITION

After allowing the engine to warm up for a few moments adjust the idle speed screw to increase the idle speed to 2,000 rpm. Turn the idle needle clockwise very slowly. This will decrease the fuel delivery to the idle system. By doing this the idle rpm will increase. Continue turning the idle needle clockwise until the peak idle rpm is reached. Once this is reached, turn the idle needle 1/8 turn rich or counterclockwise. Now, back out the idle speed screw to reduce the idle rpm until the correct idle speed is obtained. Double check the idle needle setting. At this time record what the setting is for future reference.

WPF AT WIDE OPEN THROTTLE POSITION

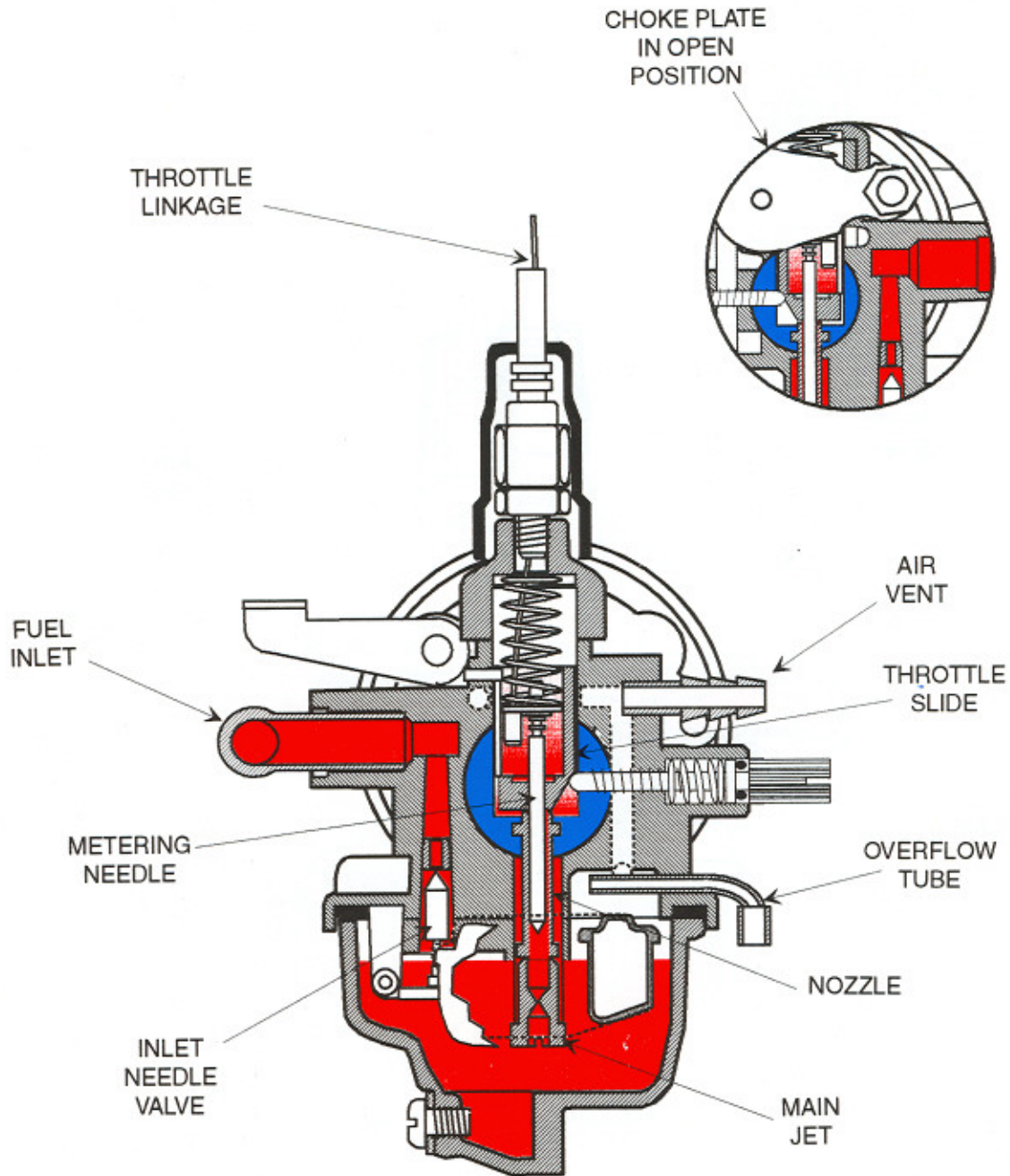

WPF AT WIDE OPEN THROTTLE POSITION

Note that the WPF carburetor is a fixed jet calibration. There is no adjustment to be made at this position.

With the WPF at the wide open throttle position the slide valve allows the attached needle to be pulled up away from the main jet to supply the correct amount of fuel required at the wide open throttle position.

Fuel delivered at the wide open throttle position enters thru the threaded main jet.

AUTHORIZED FUEL SYSTEM REPLACEMENT PARTS & TOOLS

COMPLETE ASSORTMENT
of
FLOAT FEED CARBURETORS
*
DIAPHRAGM CARBURETORS
&
COMPONENT PARTS

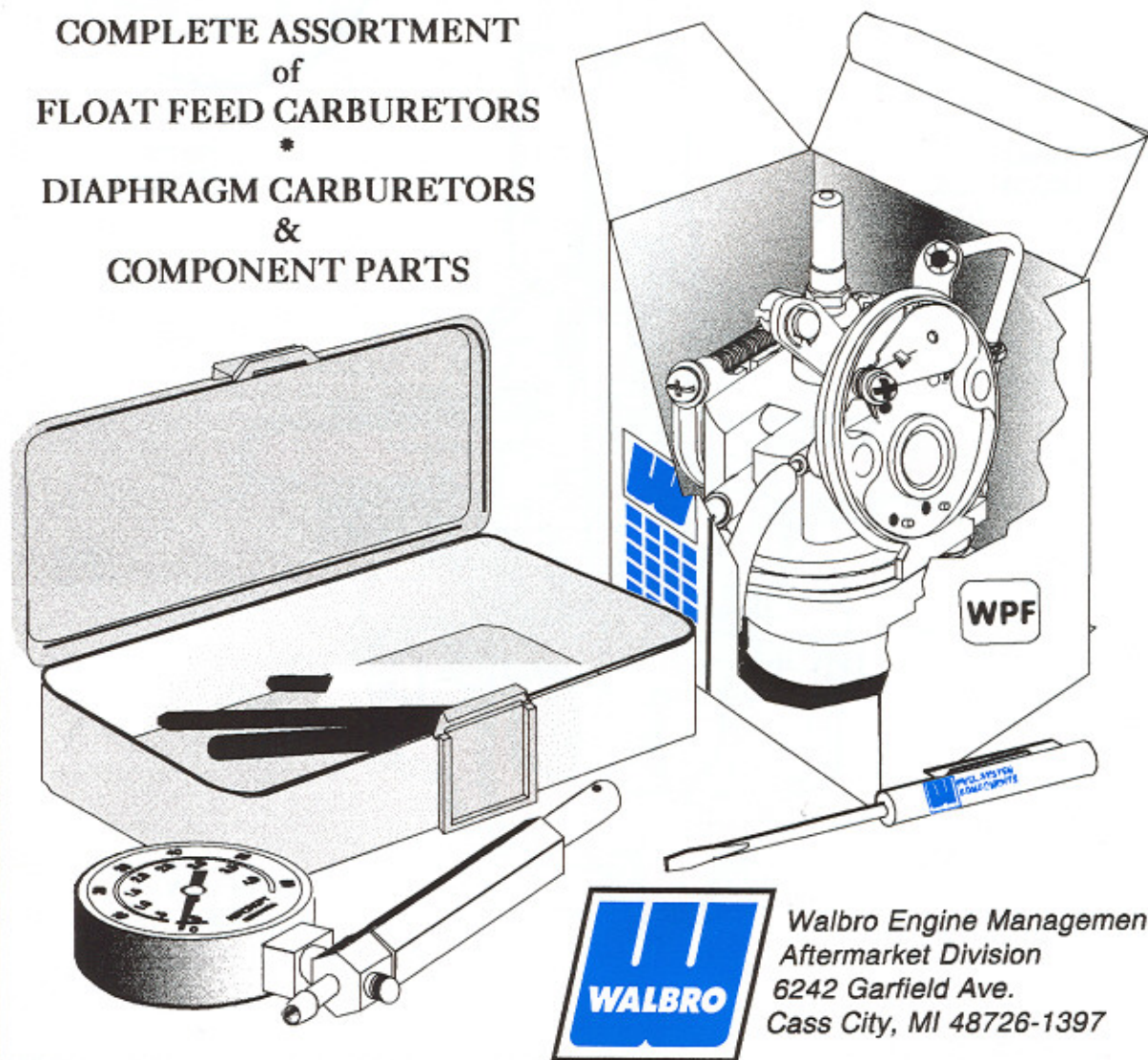

Walbro Engine Management
Aftermarket Division
6242 Garfield Ave.
Cass City, MI 48726-1397



Walbro
Engine Management
Aftermarket Division

WALBRO CORPORATION
CASS CITY, MICHIGAN